

SoundScape® Sound Wall

Solutions Brochure

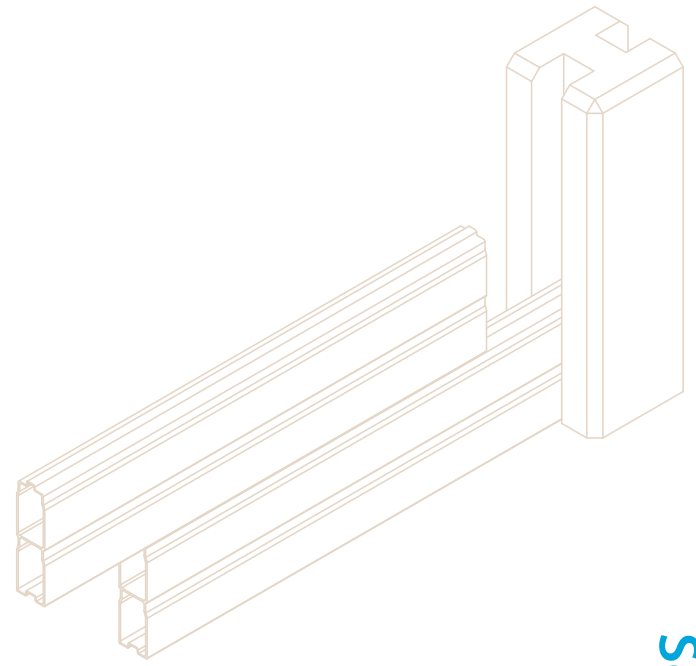

High Performance *Composite Solutions*



Spanning the Gap Between *Performance and Value.*

Custom Fiberglass Forms Division

Since 1966, Fibergrate Composite Structures has participated in over 50,000 fabrication installations worldwide. Fibergrate's design and manufacturing capabilities are global with two manufacturing facilities and worldwide distribution. As the world of composites and composite technology advances; Fibergrate leads the revolution.

Custom Fiberglass Forms, a division of Fibergrate Composite Structures, specializes in custom fiberglass reinforced plastic (FRP) products for original equipment manufacturers (OEM) and the architectural community. Custom Fiberglass Forms works directly with customers and industries to develop individualized solutions to solve old problems, create new products or improve the quality of existing products. Our design team has years of experience creating custom FRP solutions for numerous public projects like zoos, aquariums, water parks, sunscreens, fountains, pedestrian bridges and playground equipment.

Custom Fiberglass Form's premier product line begins with the Soundscape Wall Solutions' sound barrier wall. Soundscape is a fiberglass reinforced plastic barrier manufactured through a high-quality pultrusion process. Soundscape Wall Solutions has developed a superior light and noise barrier wall that meets all AASHTO and DOT guidelines. With a Sound Transmission Class (STC) of 30, the Soundscape wall will provide the needed sound reduction for congested traffic or retail areas. In addition, the class 1 fire-retardant FRP material is lightweight allowing for fast modular installation and the ability to use even in challenging terrain. The Soundscape wall can span up to 24 feet and requires no heavy equipment for installation or repairs which will minimize disruption to traffic and damage to surrounding vegetation. The FRP material will not corrode, rust or rot and is graffiti, moisture and freeze thaw resistant meaning that once it is installed, the Soundscape wall maintains its aesthetic beauty for 50 plus years of service life.

Applications

- Residential Developments
- Shopping Centers
- Industrial Sites
- Schools
- Railroads
- Highways
- Restaurants
- Commercial Sites
- Recreational Facilities



Soundscape[®] Soundwalls

The Soundscape FRP Walls provide *the* solution for sound barrier wall installations. The strength and benefits of Fibergate's FRP products continue with this product line. With the economical process of pultrusion, Soundscape planks will outperform, cost less, last longer and install faster than other noise wall options.

Soundscape Sound Barrier Features:

- ✓ Meets or Exceeds All ASSHTO and DOT Guidelines
- ✓ Modular, Lightweight Design
- ✓ Sound Transmission Class of 30
- ✓ Multiple Finish Options
- ✓ Graffiti, Moisture and Freeze Thaw Resistant
- ✓ Will Not Crack, Corrode, Rust, Warp, or Rot
- ✓ No Heavy Equipment Required for Installation or Repairs
- ✓ Stronger and More Resilient Than Other Choices
- ✓ 50 Plus Years of Service
- ✓ Lowest Life Cycle Cost
- ✓ Structurally Self Supporting: No Need for Footing Under Panels
- ✓ Optional Concrete, Steel, Wood, or FRP I-Beam
- ✓ Repairs and Modifications Can Easily Be Made On-Site

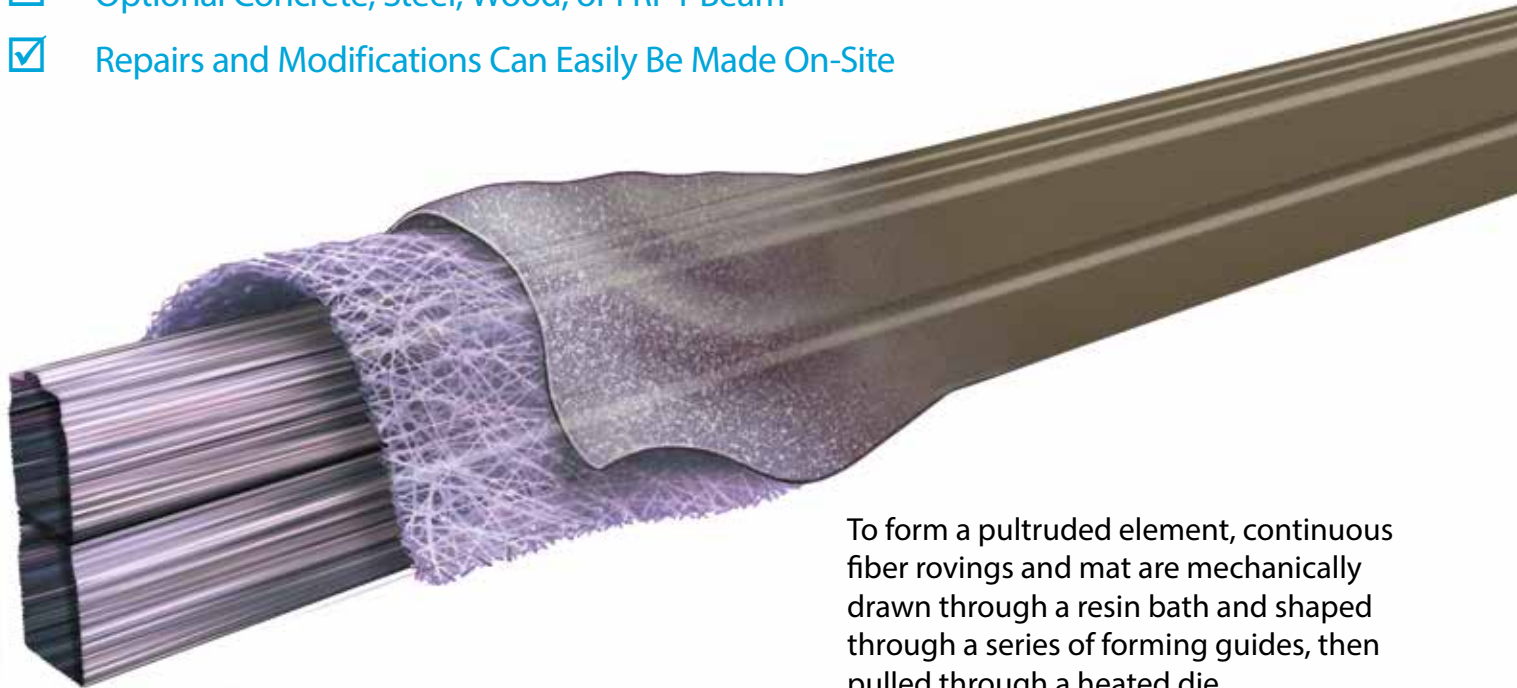

To form a pultruded element, continuous fiber rovings and mat are mechanically drawn through a resin bath and shaped through a series of forming guides, then pulled through a heated die.

Details

All Soundscape walls meet or exceed all AASHTO and DOT guidelines. Each Wall is made of interlocking tongue and groove fiberglass reinforced plastic planks set into concrete, steel, wood or FRP columns. The internal web design of the Soundscape plank minimizes deflection and allows each wall section to span up to 24 feet, greatly reducing the number of columns and caissons required for each project. The 12-inch high design minimizes the number of planks required per section while the tongue and groove configuration strengthens the assembled wall and eliminates the possibility of any gaps between stacked planks.



Soundscape Plank

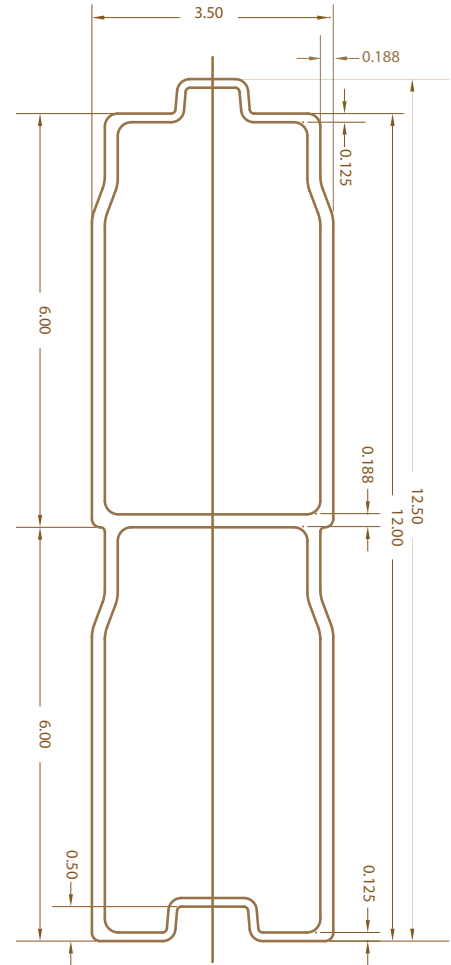

Plank weighs 4.5 lbs/ft

Soundscape Material Properties

Properties	Test	Units	Value
Flexural Strength	ASTM D790	psi	30,000
Flexural Modulus	ASTM D790	$\times 10^6$ psi	1.8
Tensile Strength	ASTM D638	psi	30,000
Tensile Modulus	ASTM D638	$\times 10^6$ psi	2.5
Compressive Strength	ASTM D695	psi	30,000
Barcol Hardness	ASTM D2583	n/a	40
Impact Resistance	ASTM 256	ft-lbs/in	25
Sound Transmission Class (STC)	ASTM E90, ASTM E413	STC Rating	30
Surface Burning	ASTM E84	Flame Spread Index	≤ 25

Drawings and Connections

Typical Soundscape

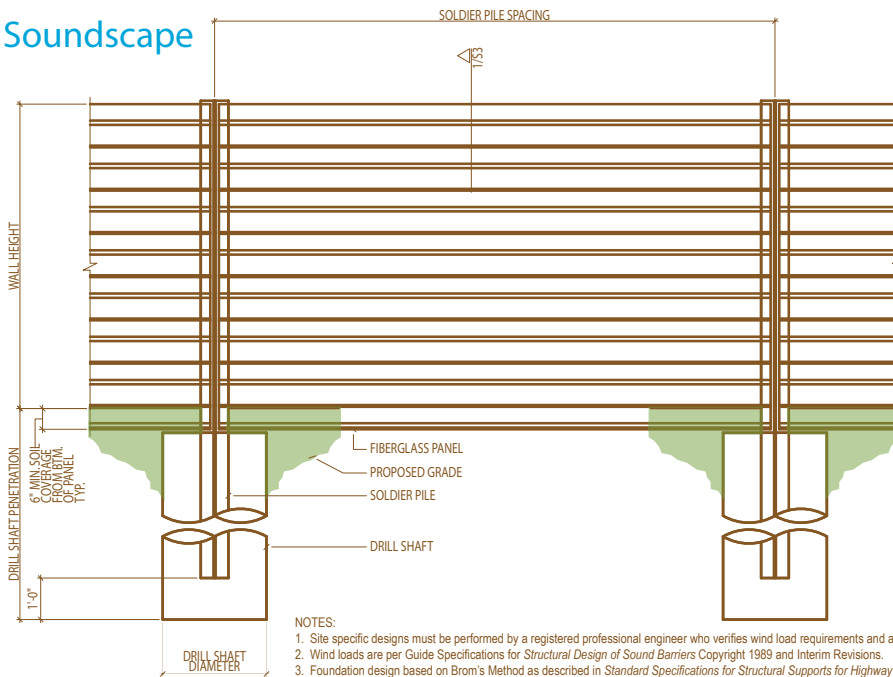

NOTES:

1. Site specific designs must be performed by a registered professional engineer who verifies wind load requirements and actual soil conditions.
2. Wind loads are per Guide Specifications for *Structural Design of Sound Barriers* Copyright 1989 and Interim Revisions.
3. Foundation design based on Brom's Method as described in *Standard Specifications for Structural Supports for Highway Signs, Luminaries and Traffic Signals 4th Edition* Copyright 2001 with Interim Revisions.
4. Structural steel member design per *Standard Specifications for Highway Bridges - Seventeenth Edition*.
5. Final deflections must be verified based on the criteria of the local governing body.

Wall Cross-Section

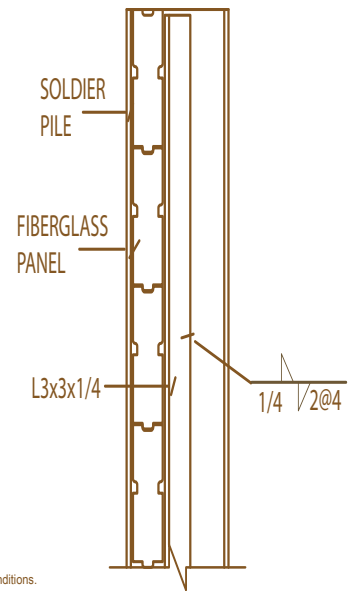

Typical Connection

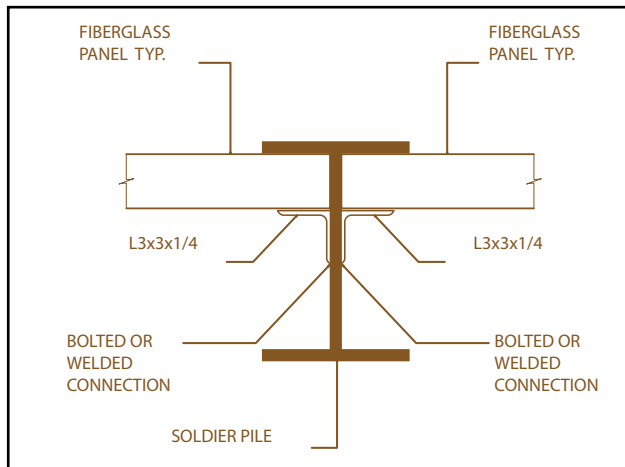

Alternate Soldier Pile Configuration

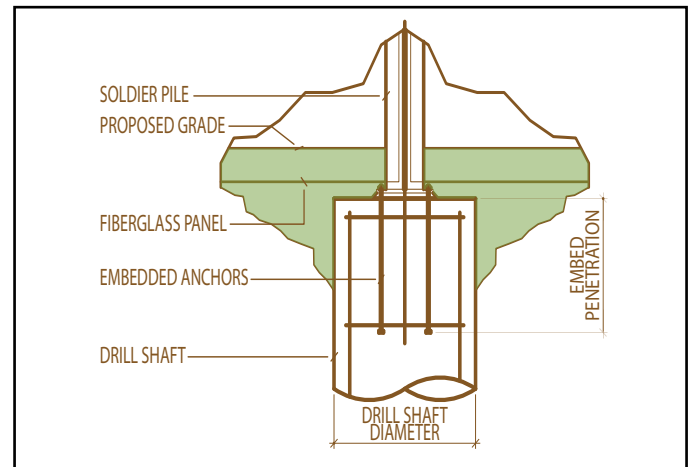

Typical Angle Connections

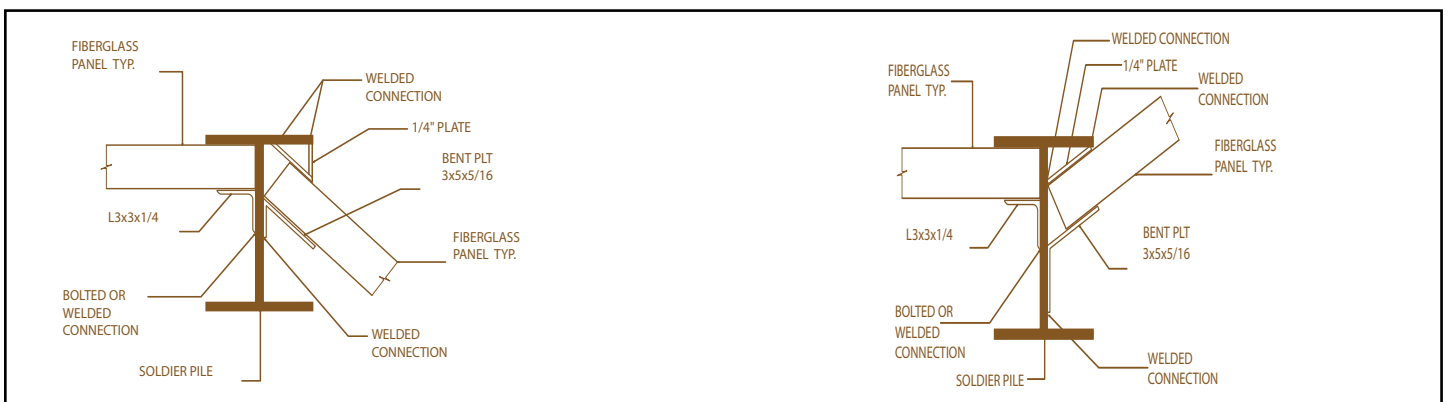

The Classic Series

The Soundscape Classic Series is a smooth “shiplap” design available in 8 standard colors. The Classic Series is finished with a graffiti-resistant high-build coating of an Aliphatic Acrylic-Polyester Polyurethane to further increase resistance to corrosion, chemical abrasion and weathering. Classic Series planks of complementary colors can also be alternately stacked to build a custom pattern throughout the wall. The Classic Series Soundscape wall is also available in any custom color.

Standard Colors

**Due to manufacturing and printing processes, colors will vary from actual product.*



SANDSTONE-33510



SAND-33617

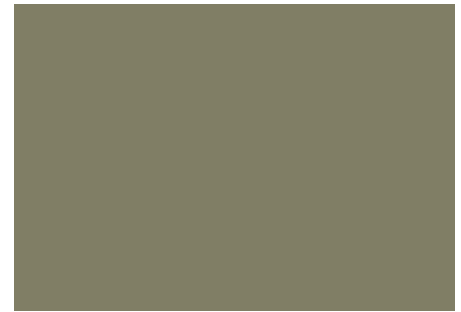

TAN GREEN-34201



GRAY GREEN-34424



BLUE GRAY-35189

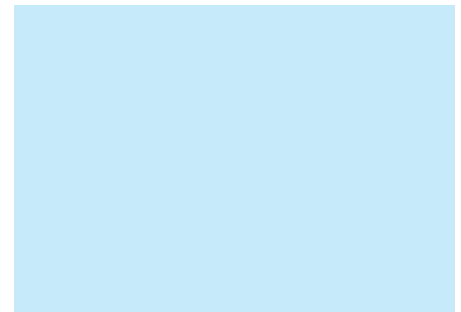

SKY BLUE-35526



AIRCRAFT GRAY-36300

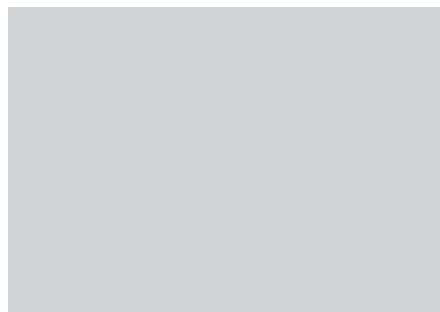

LIGHT GRAY-36495

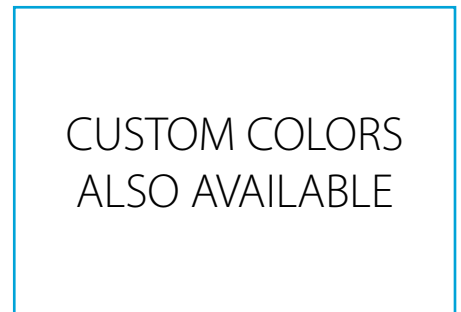

CUSTOM COLORS
ALSO AVAILABLE

The Artisan Series

The Artisan Series takes the Classic Series to a new level with the addition of a custom formulated facade of brick, block or stucco. The Soundscape Artisan Series soundwall finish consists of a blend of naturally colored quartz aggregates in a clear 100% acrylic binder over a pigmented acrylic emulsion primer and is applied using a custom template designed specifically for your project. An Artisan Series soundwall can be designed to match an existing structure or to make your wall a one-of-a-kind installation.

Aggregate Finishes

**Due to manufacturing and printing processes, colors will vary from actual product.*

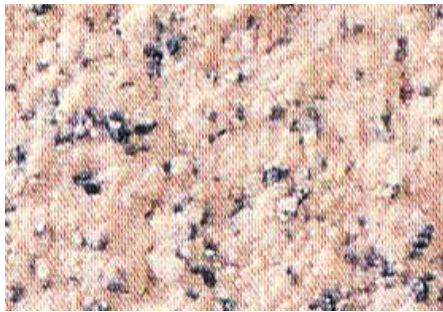

AS03 WOODBURY PINK



AS04 WHITE ASH



AS05 RIVER ROCK



AS06 CHAMPAGNE GRAY



AS02 STONY CREEK



AS07 SEDONA RED

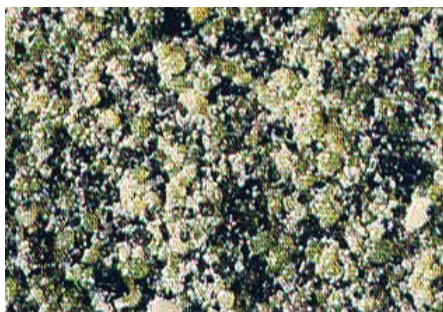

AS08 EMERALD ISLE

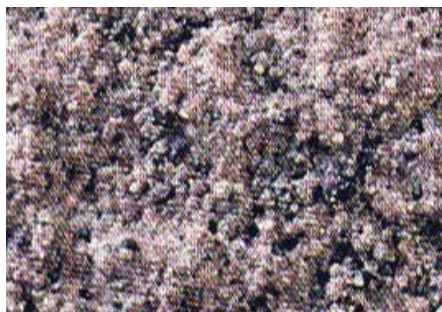

AS10 MIDNIGHT STORM

CUSTOM TEMPLATES
AND AGGREGATES
AVAILABLE

Fibergrate Products & Services



Fibergrate® Molded Grating

Fibergrate® molded gratings are designed to provide the ultimate in reliable performance, even in the most demanding conditions. Fibergrate offers the widest selection in the market with multiple resins and more than twenty grating configurations available in many panel sizes and surfaces.



Safe-T-Span® Pultruded Industrial & Pedestrian Gratings

Combining corrosion resistance, long-life and low maintenance, Safe-T-Span® provides unidirectional strength for industrial and pedestrian pultruded grating applications.



Dynaform® Structural Shapes

Fibergrate offers a wide range of standard Dynaform® pultruded structural profiles for industrial and commercial use, including I-beams, wide flange beams, round and square tubes, bars, rods, channels, leg angles and plate.



Dynarail® Guardrail, Handrail & Safety Ladder Systems

Easily assembled from durable components or engineered and prefabricated to your specifications, Dynarail® guardrail, handrail and safety ladder systems meet or exceed OSHA and strict building code requirements for safety and design.

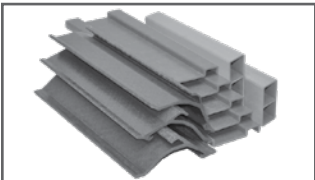

Custom Composite Solutions

Combining Fibergrate's design, manufacturing and fabrication services allows Fibergrate to offer custom composite solutions to meet our client's specific requirements. Either through unique pultruded profiles or custom open molding, Fibergrate can help bring your vision to reality.



Design & Fabrication Services

Combining engineering expertise with an understanding of fiberglass applications, Fibergrate provides turnkey design and fabrication of fiberglass structures, including platforms, catwalks, stairways, railings and equipment support structures.



Worldwide Sales & Distribution Network

Whether a customer requires a platform in a mine in South Africa to grating on an oil rig in the North Sea, or walkways in a Wisconsin cheese plant to railings at a water treatment facility in Brazil; Fibergrate has sales and service locations throughout the world to meet the needs and exceed the expectations of any customer.

Fibergrate Composite Structures Inc. believes the information contained here to be true and accurate. Fibergrate makes no warranty, expressed or implied, based on this literature and assumes no responsibility for the consequential or incidental damages in the use of these products and systems described, including any warranty of merchantability or fitness. Information contained here can be for evaluation only. The marks and trade names appearing herein, whether registered or unregistered, are the property of Fibergrate Composite Structures Inc.

©Fibergrate Inc. 2015 Soundscape Soundwall.pdf
Printed in the USA

